



TruLaser Tube

Shape the
future

Go with growth

Whether you're already in the business of conventional tube cutting or looking for new segments to enter, with high growth rates, the market for laser-cut tubes offers exceptionally good chances of success.

Tubes and profiles are used in everything from machine and system construction to the furniture industry. The introduction of laser tube cutting has forged the way for a host of new design opportunities in this area, and designers are increasingly taking advantage of laser-cut tubes and profiles. Consequently, demand for these products has increased significantly. Does your company stand to benefit from the competitive edge of laser tube cutting?

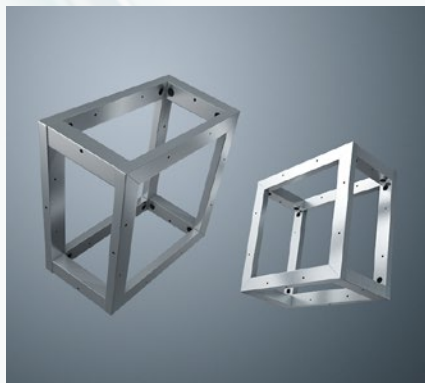
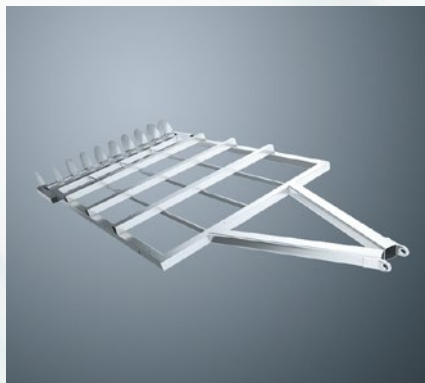

The process of laser tube cutting requires fewer steps which saves money.

The future is laser 4-5

Cutting with laser requires less time and lowers part costs.

Flexibility and efficiency 6-7

Lay the foundations for long-term success with laser tube cutting.

The road to success 8-9

Real benefits every step of the way.

Solutions that move you forward 10-11

The right machine for every job.

Our machines 12-17

Our TruConnect solutions will support you on your way to a Smart Factory.

TruConnect – Your Smart Factory 20-21

As a full service provider with individual advice and a large service network, we are always there for you.

Everything from one source 22-23

The future is laser

Pressure to manufacture products in shorter time periods and at lower costs is growing in conventional tube cutting. With the laser, entire process steps are no longer necessary, and this means immediate savings. You expand your part spectrum and your range of customers at the same time. The laser's versatility makes it possible to produce small lot sizes quickly and efficiently and offers the flexibility needed to tackle custom jobs. The broadened spectrum of design possibilities offered by laser cutting gives both manufacturers and their clients a clear competitive edge over conventional methods.



vantoro



"Laser tube cutting offers new design options with which tube processors arouse a lot of excitement in their customers. What's more, innovative designs make it possible to save a great deal of money."

Norbert Beier, Head of Sales Laser Tube Cutting



Why laser?

- Take advantage of true flexibility
- Efficient production

Flexibility and efficiency

Contouring freedom

The laser tool allows you to contour completely freely. The laser beam makes it easy to cut even the most complex contours and its intuitive controls let you produce even small, high-quality lots quickly.

Economize on tools

Laser is a single tool which allows you to process a variety of materials, wall thicknesses and profile geometries without ever having to touch the material. As opposed to working with other technologies, tool switching and costs are significantly reduced.

Lower parts costs

Laser tube cutting lets you skip entire process steps such as sawing, drilling and milling. It also cuts down on storage and handling expenses. Compared to conventional tube processing, laser significantly reduces costs for parts.

Minimize time investment

Innovative tube constructions reduce the need for downstream work such as welding and mounting. The positioning aid with pins and openings makes assembly much easier. High cutting-edge quality makes reworking the material completely unnecessary in most cases.

New business opportunities

Impress clients with products and design variants which cannot be achieved, or are not economically feasible, with conventional methods.



Flexible designer cable guide, cut from a single tube.

A comparison of the production steps involved in laser tube cutting and conventional manufacturing

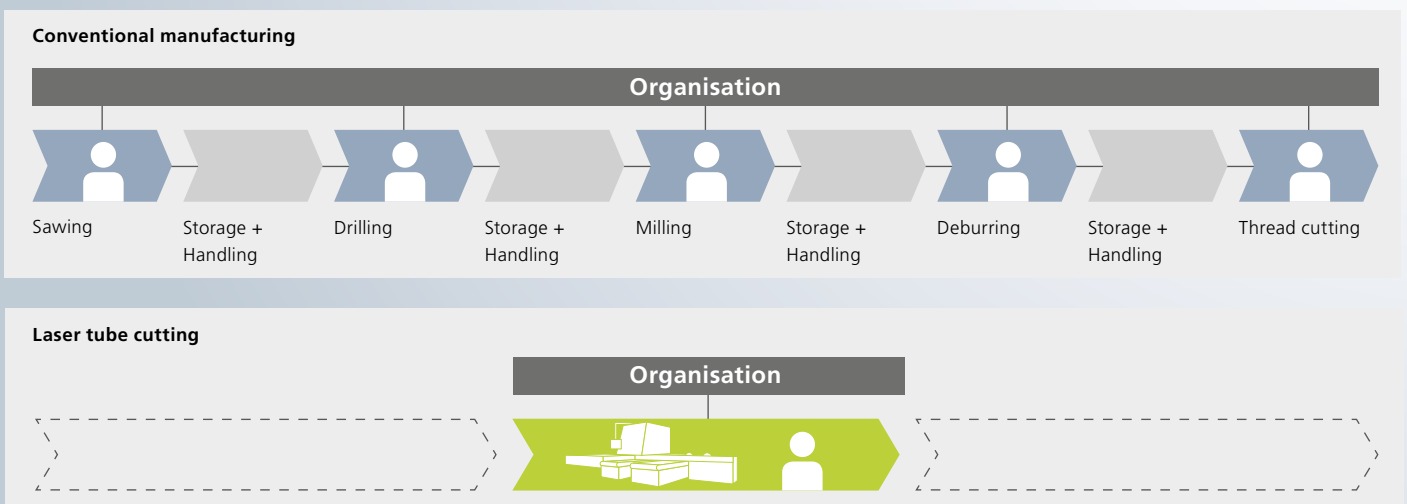

Simply efficient

Taking the example of a bending connection, laser tube cutting is 49% more time-efficient and 31% more cost-efficient per part.

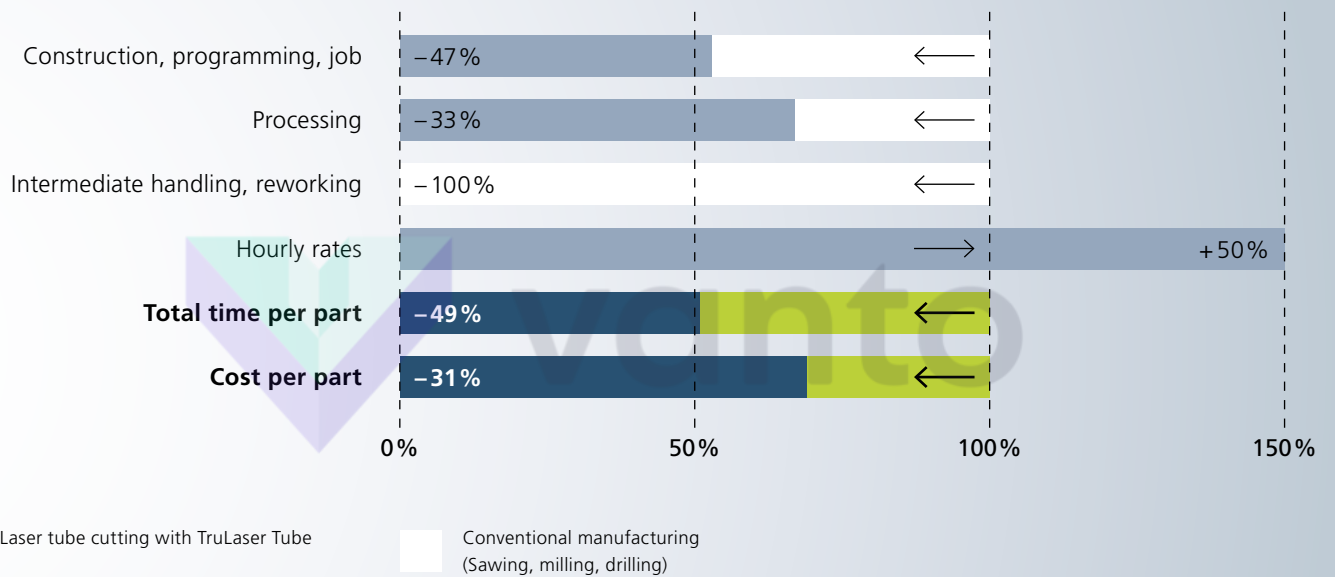

Conventional welding of two separate parts.



Efficient production of bend connections and positioning aids using a laser.

Set a course for success

Set a course for success in the long term with laser tube cutting. Choose the right partner for this – as a global market leader in laser technology and in machine tool engineering, we are an innovative pioneer in the market and can provide you with the perfect solutions for the world of laser tube cutting.

Complete support

Instead of bought-in components, at TRUMPF you are provided with everything from a single source: machine, laser, optical system, automation, software, and service.

Expertise included

Start immediately – with our tried-and-tested package of machines suitable for industrial use, simple operation, as well as technology and cutting data.

Future-proof

We have been a laser specialist for more than three decades and invest more than average in the development of tube cutting technology. This means we are always one step ahead of the competition.



TruTops Tube programming system with 3D tube construction

TruTops Tube is a technology-oriented programming system developed by TRUMPF for tube and profile processing using laser tube cutting machines. TruTops Tube not only provides you with a CAD/CAM system, but also TRUMPF's technological expertise. A 3D tube construction module is part of the programming system, meaning that there is not only the option to import existing 3D data, but also to design new parts with ease.

Flexible imports

The 3D tube interface allows you to process 3D data from CAD systems in all common formats, such as SAT, IGS or STP. This enables imported files to be prepared automatically in line with production, and tube profiles to be detected for direct further processing.

These and other innovative tube designs can be implemented, for example, with the 3D tube construction and TruTops Tube:

Positioning aids

Positioning aids can be designed at the press of a button. They can be used to simplify downstream production steps such as assembly or welding tasks. Rejects are therefore considerably reduced.

Bend connections

Produce corner connections, which would have normally been created from two tubes, quickly and easily – now by simply bending the tube. This increases productivity during assembly.

Curved tubes

Curved tube models can be converted into straight tube sections for laser tube cutting quite easily. Here, the input of adjustment values is possible at all times. Contours outside the bending zone remain at the correct coordinates.

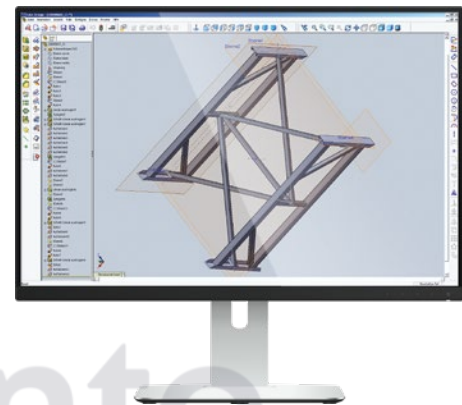
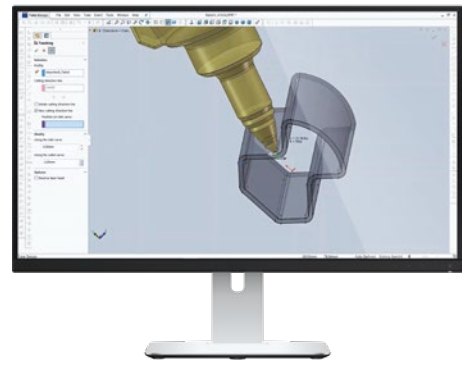

Solutions that take you forward

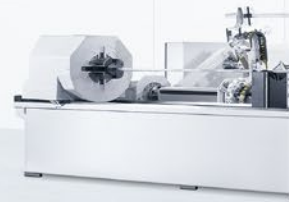

With clever functions and integrated expertise, we support the path of your tubes and profiles through the machine. Each component aims to optimize your results. Benefit in each step.

Loading

How can I load special profiles in a process-reliable way?

You can even load special profiles automatically with sensor support due to **Smart Profile Detection**. Here, the rotational position and orientation of the profile is detected and then aligned according to the cutting program.

Can I align my tubes automatically?

Yes. With **SeamLine Tube**, weld seams or marks on the outside, and optionally on the inside, of the tube are detected. This ensures the correct alignment of each tube to the cut geometry on your machine.

How can I produce small lot sizes quickly and efficiently?

With the swiveling **manual conveyor system**, you can create small lot sizes in just a few steps. For this, there is no need to empty the bundle space, which may still be filled with tubes for a larger order. Loading is automatic and also perfectly suited to special profiles.

Cutting

How can I increase productivity for material thicknesses up to 3 mm?

With the **RapidCut** function, the high feed rates of the solid-state laser make an impact even with small contours. Through this, you can process your parts up to 30% faster.

Can I optimize the piercing process?

Using **PierceLine**, the piercing times can be reduced by 10 to 60% compared to preset values, depending on material type and material thickness.

Do I have to change the cutting head for different sheet thicknesses?

No. With TRUMPF, you can say good-bye to frustrating changes of the cutting head. Due to the **one-cutting-head strategy**, you can cut all wall thicknesses with one and the same cutting head.

How do I protect my cutting head and avoid collisions?

With the aid of the **ControlLine** function, the distance between the cutting nozzle and the surface remains constant, even for uneven tube surfaces. The magnetic coupling minimizes the impact of unavoidable collisions.



Unloading

Can I sort my parts according to order?

Finished parts can be removed into wire mesh boxes, for example, or customer-specific containers. Conveyor tables in particular enable you to unload at an ergonomic height, whilst protecting the material.

Can I automate the loading and unloading process even further?

Using the **digital unloading interface** you can connect a robot, for example, and thereby automate the loading and unloading process even further.

Simplify downstream processes

How can I optimally prepare bevel edges?

The **bevel cut** function with patented TRUMPF technology enables high-quality bevel cuts up to 45°.

How can I create threads in one work step?

Creating threads manually is time-consuming and prone to errors. Simply integrate this work step into your machine. With the **technology package for tapping**, you can carry out processes such as twist drilling, thread cutting, flow drilling, and tapping using an NC-controlled spindle unit.

The insides of my tubes are very dirty.

How can I change this?

Round tubes can be processed in a low-spatter manner using the **spatter protection device** on the inside. This saves you time spent reworking. Depending on requirements, you can also do without reworking completely.

How can I identify my parts?

With the **Dot Matrix Code** you always know what part you are looking at and what needs to be done with it.

TruLaser Tube 5000 fiber

Solid-state laser technology means quick and flexible processing. The TruLaser Tube 5000 fiber is built on these strengths like no other laser tube cutting machine.

With Central Link, the interface for Industry 4.0



01

Highly productive

with solid-state laser and RapidCut

02

Setup time

virtually none

01

Highly productive

with solid-state laser and RapidCut

Thanks to RapidCut, the solid-state laser's high feed rate is already noticeable on small contours. This represents a huge plus for productivity when processing thin sheet material.



With RapidCut, you can reduce part times for material thicknesses of up to 3 mm.

02

Setup time

virtually none

Setup is now a thing of the past, thanks to the TruLaser Tube 5000 fiber's clamping method. Tubes can be processed across the entire clamping range without the need for modifications.

Technical details			
Max. outside diameter of round tubes	mm	152*	
Max. outer circle diameter of rectangular tubes	mm	170	
Max. raw material length for automatic loading	mm	6500/8000**	
Max. finished part length	mm	3000/4500**/6500**/8000**	
Max. weight of workpiece	kg/m	20 (130/160** kg in total)	
Laser details		TruDisk 2001	TruDisk 3001
Max. output	kW	2	3
Average power consumption in production	kW	8	9
Max. material thickness			
Mild steel	mm	8	8
Stainless steel	mm	4	5
Aluminum	mm	2	6
Copper/brass	mm	3	4

* Manual loading of round tubes with outside diameter of 152–170 mm optionally possible. ** Figure applies to larger model (optional). Subject to alteration. Only specifications in our offer and order confirmation are binding.



04

Easily expandable

for follow-up processes such as tapping

03

Easy access

thanks to the intelligent beam guard

03

Easy access

thanks to the intelligent beam guard

Tube processing with a solid-state laser can also be done without a complete housing – the TruLaser Tube 5000 fiber’s open machine concept guarantees easy access. Individual tubes can be quickly and easily loaded and unloaded from the front.



The innovative clamping method removes nearly any need for setup.

04

Easily expandable

for follow-up processes such as tapping

Simply integrate additional processes: With the technology package for tapping you can carry out machining processes such as flow drilling, tapping, and twist drilling. In the laser network, you can operate several TRUMPF machines with one laser.

TruLaser Tube 5000

Open and modular down to the last detail. The machine concept has proven its worth worldwide, through the course of day-to-day industrial processes – it is an ideal choice for entry into laser tube processing.

With Central Link, the interface for Industry 4.0



01

Open machine design

Keeping an eye on everything, at all times

02

Modular installation

customized to your requirements

01

Open machine design

Keeping an eye on everything, at all times

Due to the machine's open design, the operator can keep an eye on the entire process at all times. The exceptional accessibility makes it possible for individual tubes to be loaded and unloaded quickly.

02

Modular installation

customized to your requirements

Install your TruLaser Tube in line with your requirements. Here, you can place the LoadMaster Tube either in front of or behind the machine, as desired. You can set up conveyor tables, wire mesh boxes, and containers on the unloading side.

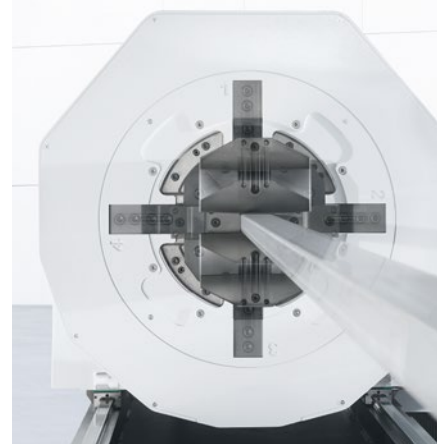

Due to the innovative clamping system, you can produce with virtually no setup.

Technical details

Max. outside diameter of round tubes	mm	152*		
Max. outer circle diameter of rectangular tubes	mm	170		
Max. raw material length for automatic loading	mm	6500/8000**		
Max. finished part length	mm	3000/4500**/6500**/8000**		
Max. weight of workpiece	kg/m	20 (130/160** kg in total)		
Laser details		TruFlow 2000	TruFlow 2700	TruFlow 3200
Max. output	kW	2	2.7	3.2
Average power consumption in production	kW	17	20	24
Max. material thickness				
Mild steel	mm	8	10***	10***
Stainless steel	mm	4	5	5
Aluminum	mm	3	4	4

* Manual loading of round tubes with outside diameter of 152–170 mm optionally possible. ** Figure applies to larger model (optional).

*** With PierceLine (optional).

Subject to alteration. Only specifications in our offer and order confirmation are binding.

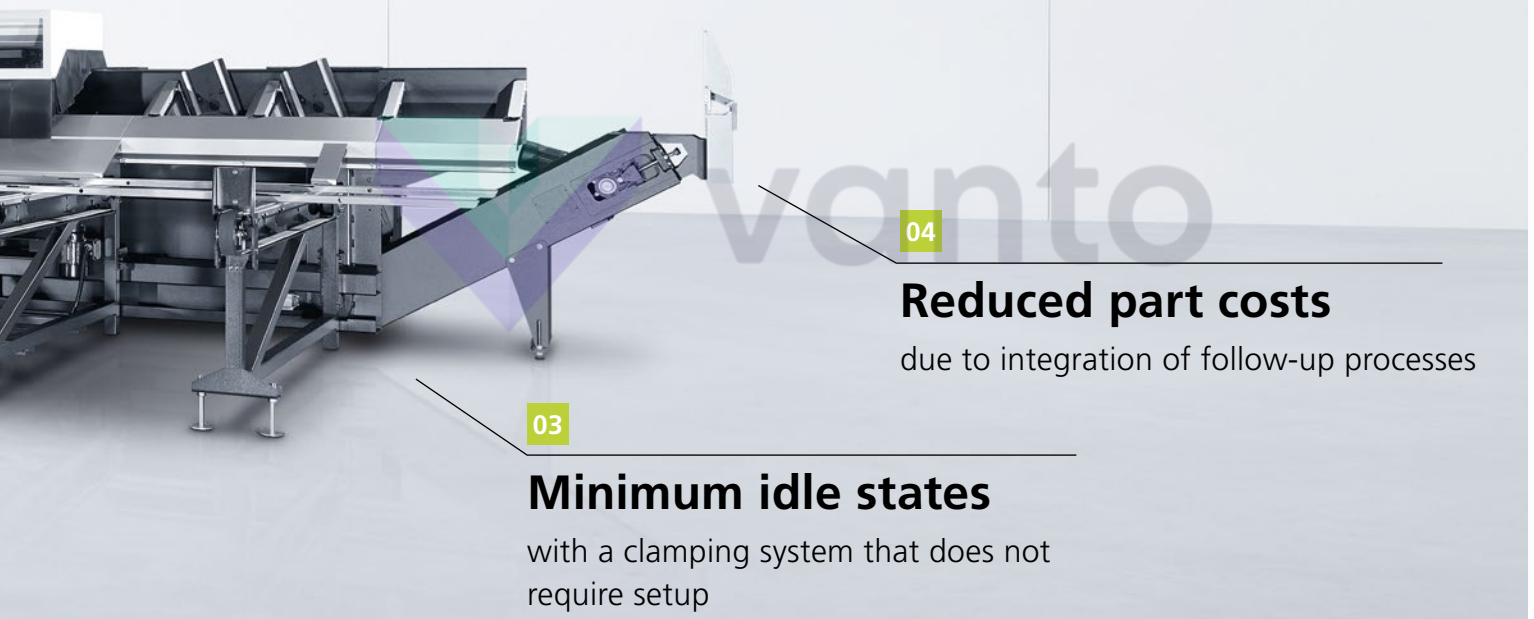

04

Reduced part costs

due to integration of follow-up processes

03

Minimum idle states

with a clamping system that does not require setup

03

Minimum idle states

with a clamping system that does not require setup

Setting up means increased expense – especially for small lot sizes. Due to the innovative clamping system of your TruLaser Tube 5000, you can produce tubes in the entire clamping range with virtually no setup.

04

Reduced part costs

due to integration of follow-up processes

By integrating upstream and downstream processes into the TruLaser Tube 5000, you save time and money. For example with the technology package for tapping, you can produce threads even in thin materials, due to flow drilling. You avoid having to travel from one machine to the next and in doing so, reduce part costs and the risk of errors.



The technology package for tapping makes flow drilling easily viable.

TruLaser Tube 7000

With Central Link, the interface for Industry 4.0

Our flexible high-end machine for XXL laser tube cutting.



01

Highly flexible
for tubes up to 254 mm

02

Sorting included

via flexible part-removal station

01

Highly flexible
for tubes up to 254 mm

The TruLaser Tube 7000 is the choice for XXL laser tube cutting. Process tubes and profiles with diameters up to 254 mm and wall thicknesses of up to 10 mm on mild steel. The perfect machine for all jobs: process small, rectangular, round and oval tubes.

02

Sorting included

via flexible part-removal station

The flexible part-removal station sorts the finished parts onto a movable conveyor table, into wire cages or into transport containers, as desired. All components can be placed freely.



Suitable for thick, thin, small, and large tubes.

Technical data				
Max. outside diameter of round tube	mm	204/254*		
Max. outer circle diameter of rectangular tube	mm	204 / 254*		
Max. unprocessed material length for automatic loading	mm	6500/9200*		
Max. finished part length	mm	3000/4500*/6000*/6500*/8000*		
Max. workpiece weight	kg/m	25 (150 kg total) / 37.5** (225 kg total)**		
Laser data		TruFlow 2000	TruFlow 2700	TruFlow 3600
Max. power	kW	2	2.7	3.6
Average power input in production	kW	20	23	26
Max. material thicknesses				
Mild steel	mm	8	10***	10***
Mild steel	mm	4	5	6
Aluminum	mm	3	4	5

* Value for larger versions (option). ** Value for the version with max. outer circle diameter 254 mm (option). *** With Pierceline (option). Subject to alteration. Only specifications in our offer and order confirmation are binding.



04

Efficient from lot size 1
due to open machine design

03

Integration
of follow-up processes

03

Integration
of follow-up processes

Carry out follow-up processes on your machine with ease: with the optional technology package for tapping, for example, you can carry out machining processes such as flow drilling, tapping, and twist drilling – automatically. Upon request, the spatter protection device protects the insides of your tubes against dirt, and in doing so reduces the need for reworking.

04

Efficient from lot size 1
due to open machine design

The machine is designed closely in line with the operator’s needs: Even individual tubes can be loaded quickly from the front and easily by hand. This makes it efficient from a lot size of 1. The swivel-mounted conveyor system is ideal for small series and special profiles.



For small lot sizes and special profiles you can use the swivel-mounted conveyor system.

TruLaser Tube 7000 fiber

Highest level of productivity – even for XXL tubes.

With Central Link, the interface
for Industry 4.0



01

Dynamic and productive

with solid-state laser and RapidCut

02

XXL

Tubes up to 254 mm diameter

01

Dynamic and productive

with solid-state laser and RapidCut

The superimposed movement of the tube axis and cutting head increases the dynamics of your machine by more than four times. Due to RapidCut, the high feed rates of your solid-state laser make an impact even with smaller contours. Above all, this means an enormous plus for productivity in the case of thin material.



With RapidCut, you accelerate your production by up to four times.

02

XXL

Tubes up to 254 mm diameter

Whether large or small, thick or thin: With your TruLaser Tube 7000 fiber you can cut a broad spectrum of parts. This includes even extra-large tubes and profiles with diameters up to 254 mm, and wall thicknesses of up to 10 mm for mild steel.

Technical data			
Max. outside diameter of round tube	mm	254	
Max. outer circle diameter of rectangular tube	mm	254	
Max. unprocessed material length for automatic loading	mm	6500/9200*	
Max. finished part length	mm	4500 / 6000* / 6500* / 8000*	
Max. workpiece weight	kg/m	40 kg/m (225 kg total)**	
Laser data		TruDisk 3001	TruDisk 4001
Laser data	kW	3	4
Average power input in production	kW	9	11
Max. material thicknesses			
Mild steel	mm	8	10
Stainless steel	mm	5	6
Aluminum	mm	6	6
Copper / brass	mm	4	4

* Value for larger versions (option). ** For manual loading total weight max. 40 kg/m.
 Subject to alteration. Only specifications in our offer and order confirmation are binding.

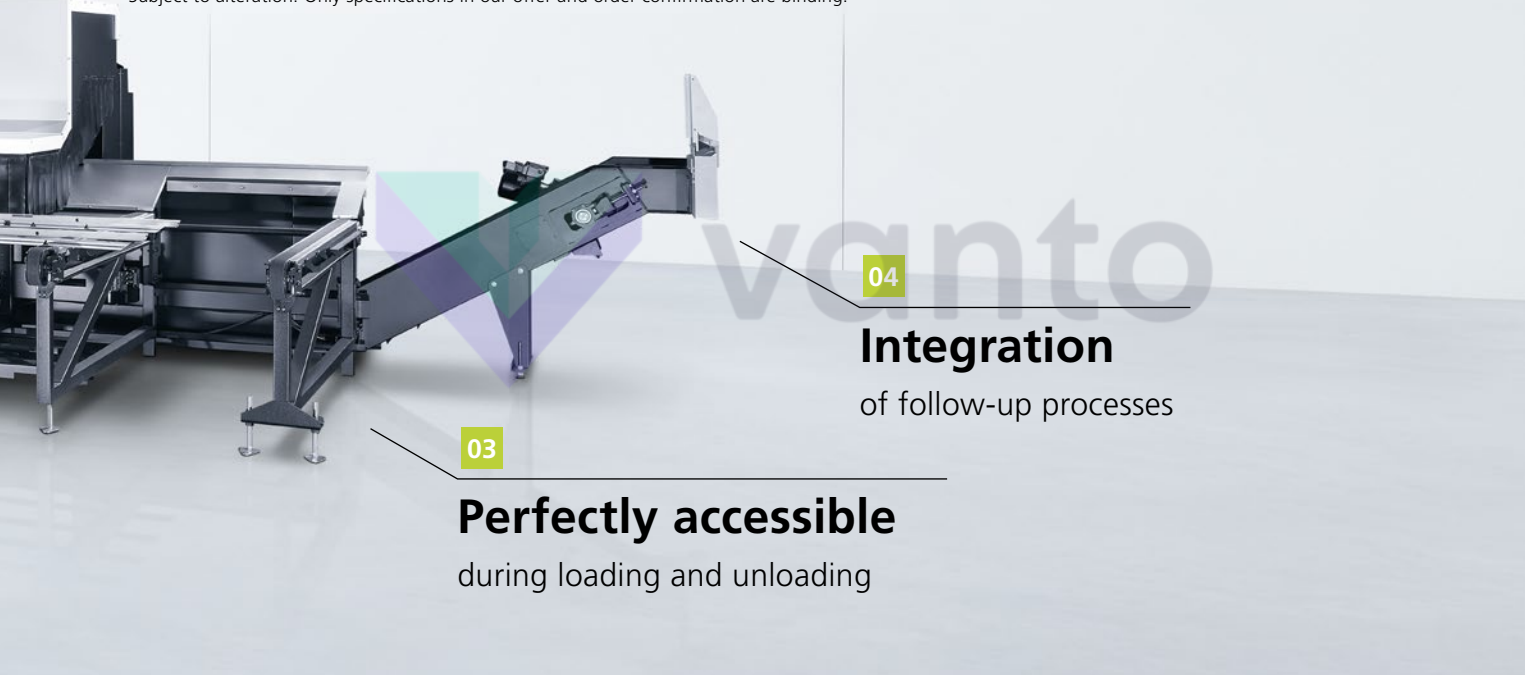

03

Perfectly accessible
 during loading and unloading

04

Integration
 of follow-up processes

03

Perfectly accessible
 during loading and unloading

The open machine concept makes your TruLaser Tube 7000 fiber optimally accessible. This allows you to load individual XXL tubes – such as by crane – quickly and efficiently. For small lot sizes and special profiles you can use the swivel-mounted conveyor system.



Ideal for lot sizes of 1: Crane loading also possible for heavier tubes.

04

Integration
 of follow-up processes

Carry out follow-up processes on your machine with ease: with the optional technology package for tapping, for example, you can carry out machining processes such as flow drilling, tapping, and twist drilling – automatically.

TruConnect – Your Smart Factory



80%

Indirect processes make up 80% of your production time – this represents the greatest potential for savings.



Discover the potential networked production could unlock for you with these two example scenarios:
www.trumpf.com/s/smart-factory

Gain more freedom with digital networking: You see more, know more, and get the best out of your laser systems and your overall production. With TruConnect, the synonym for Industry 4.0 at TRUMPF, you can design your Smart Factory step by step. The pragmatic solutions from TRUMPF support you on your path towards networked production, helping you to make your entire process more transparent, more flexible, and above all more efficient.

For companies big and small

From the simple product solution right through to fully networked production.

- **Getting started** with machines that are equipped for networking as standard
- **Improving gradually** with automated machines or autonomous processing cells embedded in a production solution
- **Entirely connected** with a continuous production solution, from order to delivery

Smart functions and Industry 4.0

With the MobileControl app you can operate and monitor your machine easily and flexibly: It transfers the standard control panel interface to the touchscreen of your tablet. Thanks to the Central Link interface, your TruLaser machine is ready for Industry 4.0.



You can monitor and control your machine in the machine environment with the MobileControl app.



You can find more information about networked production here:
www.trumpf.com/smart-factory

Perfect interaction for your success

From the machine to the laser and the optical system, to the technology data: Intelligent machine functions are based on the interaction between different components. This is why we develop and manufacture them ourselves. The result? Consistent solutions down to the details – the ideal basis for your success.



The result

You receive a production system that is always available, comprising components with perfect interplay.

TruServices

With comprehensive services and a global service network, we are always there for you.

Software

You optimize your production processes with software solutions from TRUMPF. The TruTops Tube programming system is optimally designed for your machine.

Automation

Many automation components are available for your TruLaser Tube machine, for example, the LoadMaster Tube for loading your tubes.

Process expertise

Every machine contains updated technology data checked by TRUMPF for laser tube cutting – so you can get started right away.

Optical system

We develop lasers, fiber optic laser cables and cutting heads for each specific set of requirements and for every series. The benefit to you: You can make the best possible use of the power of your tool.

Machine

All TruLaser Tube machines are developed and produced by TRUMPF – they are a robust solution for your day-to-day industrial applications.

Commitment is what drives us

Whether manufacturing and production technology, laser technology or material processing: We develop highly innovative products and services for you that are industry standard and completely reliable. In order to offer you persuasive competitive advantages, we give it our all: Expertise, experience and plenty of commitment.



Visit our YouTube channel:
www.youtube.com/TRUMPFtube
www.trumpf.info/97b623



Lasers for production technology

Whether macro, micro or nano: We have the right laser and the right technology for any industrial application, allowing you to manufacture in an innovative yet cost-efficient manner. As well as the technology, we will also support you with system solutions, knowledge of applications and advice.



Power supplies for high-tech processes

From semi-conductor production to manufacturing solar cells: Our high- and medium-frequency generators give electricity for induction heating, plasma and laser excitation a defined form based on frequency and demand – highly reliable and with repeat accuracy.



Machine tools for flexible sheet and raw processing

Laser cutting, punching, bending, laser welding: For all processes in flexible sheet production, we offer you custom-fit machines and automation solutions, including consultancy, software, and services – enabling you to produce your products reliably and in high quality.



Industry 4.0

The TruConnect range of solutions connects man and machine through information. It covers all steps of the production process – from offer to shipping your parts.

