

THE K-TEC SERIES

400 to 4,500 kN



Global Partners in Plastics

K-TEC

High Performance Injection Molding Machines

Exceptional precision and repeatability, fast cycle times, high injection rates and pressure, parallel functions, and easy maintenance: these are the hallmarks of the K-TEC, one of the most productive injection molding machines available on the market today.

High performance hydraulic and hybrid K-TEC machines help keep injection molders in the lead by offering competitive manufacturing solutions for everything from the simplest to the most demanding applications, including multi-cavity molding, challenging material combinations and integrated process molding.

From Standard Machines to Customized Production Cells

With the proven modular design of the K-TEC, Ferromatik Milacron engineers can quickly provide effective real-world solutions for any application. Our experts guide you through the process from machine selection and optimization, through part design, to complete process solutions – including mold, automation and auxiliary equipment.

K-TEC 40 · 60 · 85 · 110 · 155 · 175 · 200 · 250 · 275 · 320 · 350 · 400 · 450

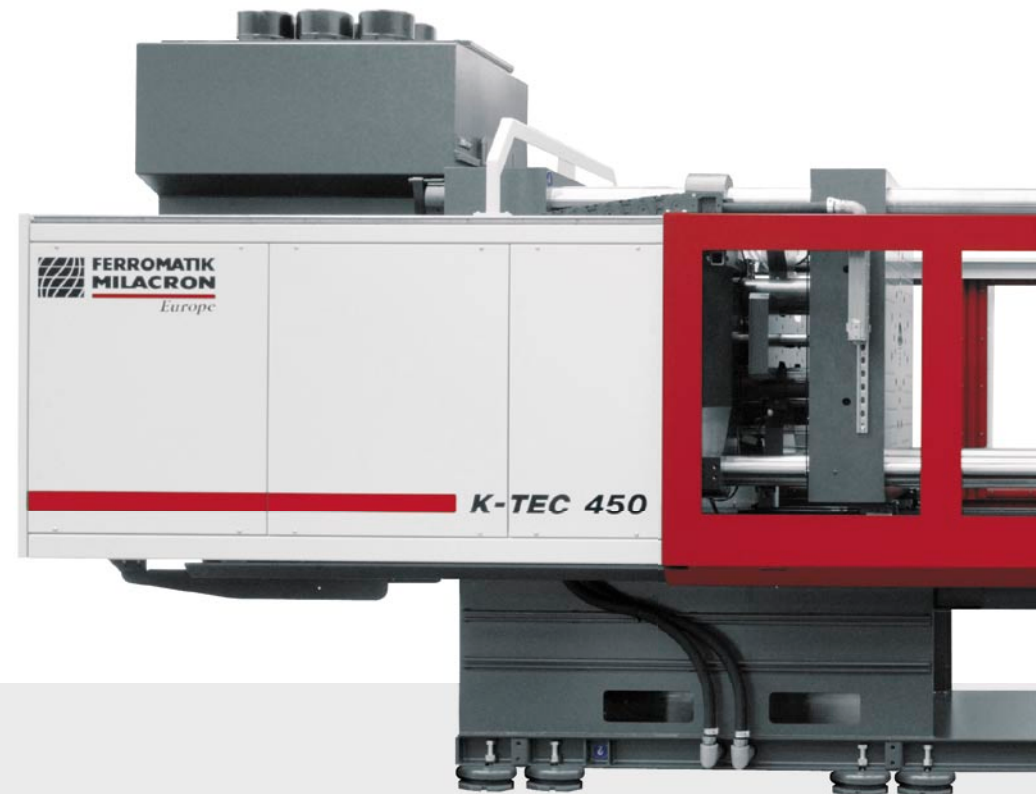

Typical Applications

Packaging

Caps · Closures · Cups · Buckets · Containers

Consumer Goods

Razors · Toothbrushes · Sporting goods · Writing instruments · Toys

Appliances

Hair dryers · Vacuum cleaners · Air conditioners

Electrical & Telecommunication

Switches · Connectors · Sensors · Telephones · Computers

Medical

Syringes · Inhalers · Catheters

Automotive & Transport

Interiors · Exteriors · Lighting

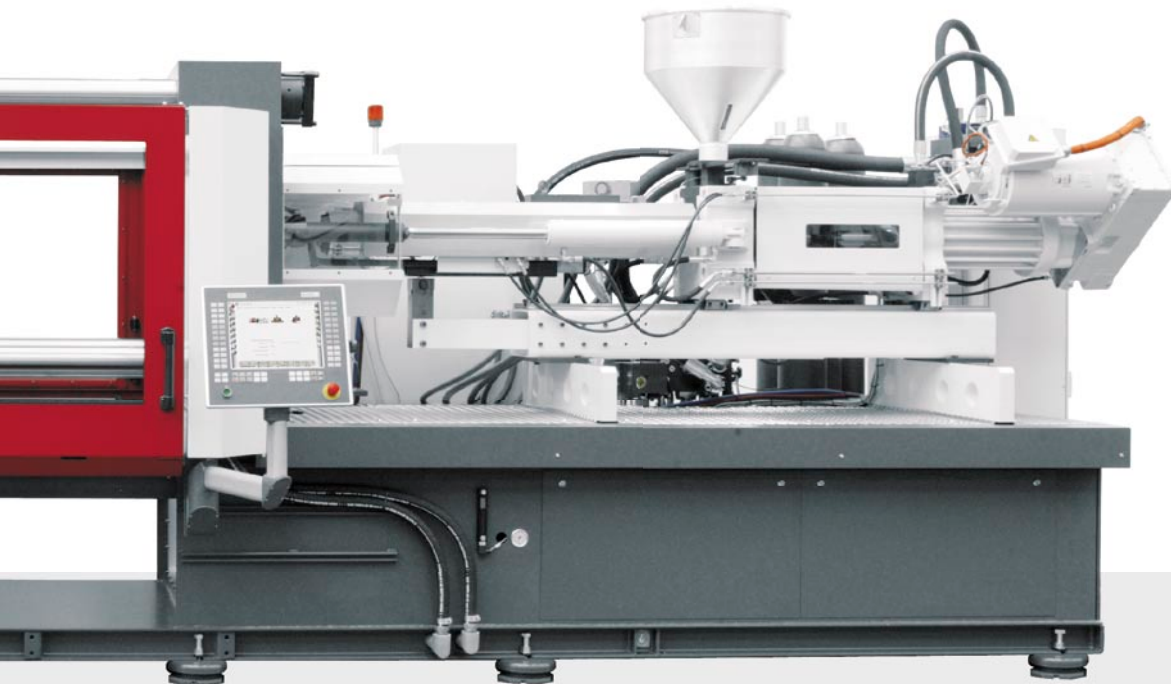

Ferromatik Milacron – Part of the Milacron Team

Plastics make our lives better: more convenient, safer, and more colorful. For over 50 years Ferromatik Milacron has been building injection molding machines for plastics manufacturers at our facility in Malterdingen, Germany. With a workforce of 500 and offices in 50 countries, Ferromatik Milacron machines are sold worldwide. As part of the Milacron group, founded in 1884, Ferromatik Milacron enjoys the backing of a global company with 3,500 employees.



Main facility in Malterdingen



Flexible production system



K-TEC assembly

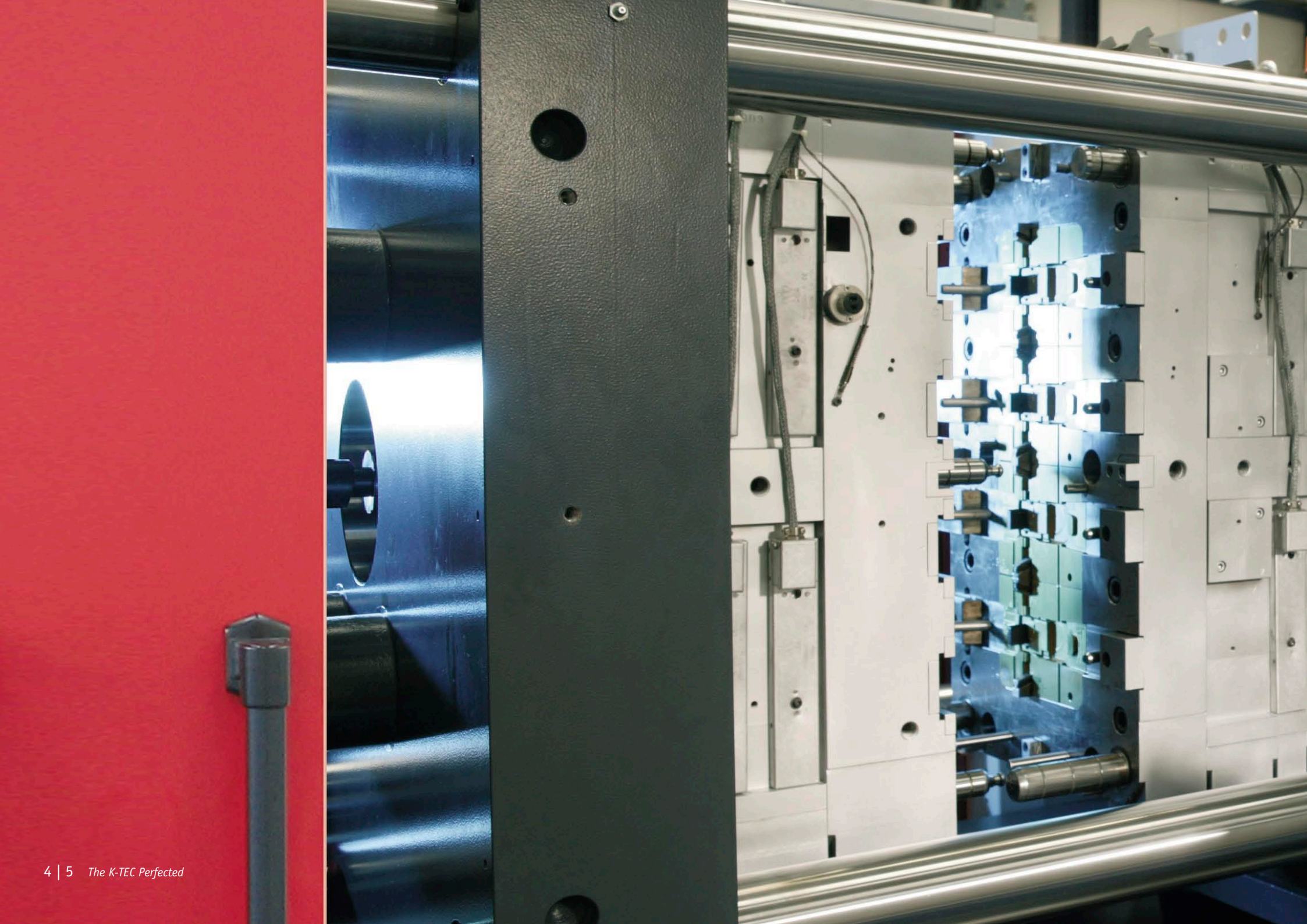



**FERROMATIK
MILACRON**

MOSAIC

- 1 2
- 3 4
- 5 6
- 7 8

Schließereinheit: Einstellungen

Einstellungen | Öffnen / Schließen | Auswerfer | Luftventile

12.09.2007 15:09

Werkzeugposition 380.04 mm

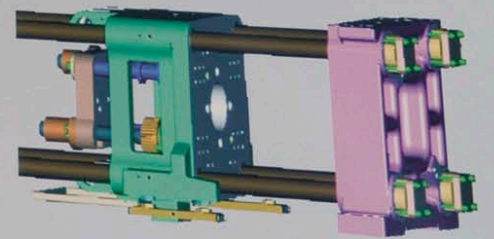

Einstellungen

Einrichtdrehmoment 20.0 0.1

THE PROOF IS IN THE PARTS

Superior Precision and Repeatability

The three-platen clamp, constructed from rigid materials, is designed to provide maximum platen parallelism within the whole work area. Combined with a centrally applied clamping force, this ensures above-average mold longevity. K-TEC precision is assured by:

- Reduced platen deflection allowing for lower clamp tonnage, less mold wear, and better part quality – especially with large multi-cavity molds
- The pressure controlling the movement is highly responsive at high speeds providing superb mold protection
- Mold weight supported by machine base via roller bearings, reducing stress to tie bars and ensuring clamping unit accuracy
- The clamping unit design provides high process stability through automatic thermal expansion compensation
- Steel platens with custom centering for higher rigidity
- Dedicated reservoir above clamping cylinder ensures fast oil transfer during opening and closing movements



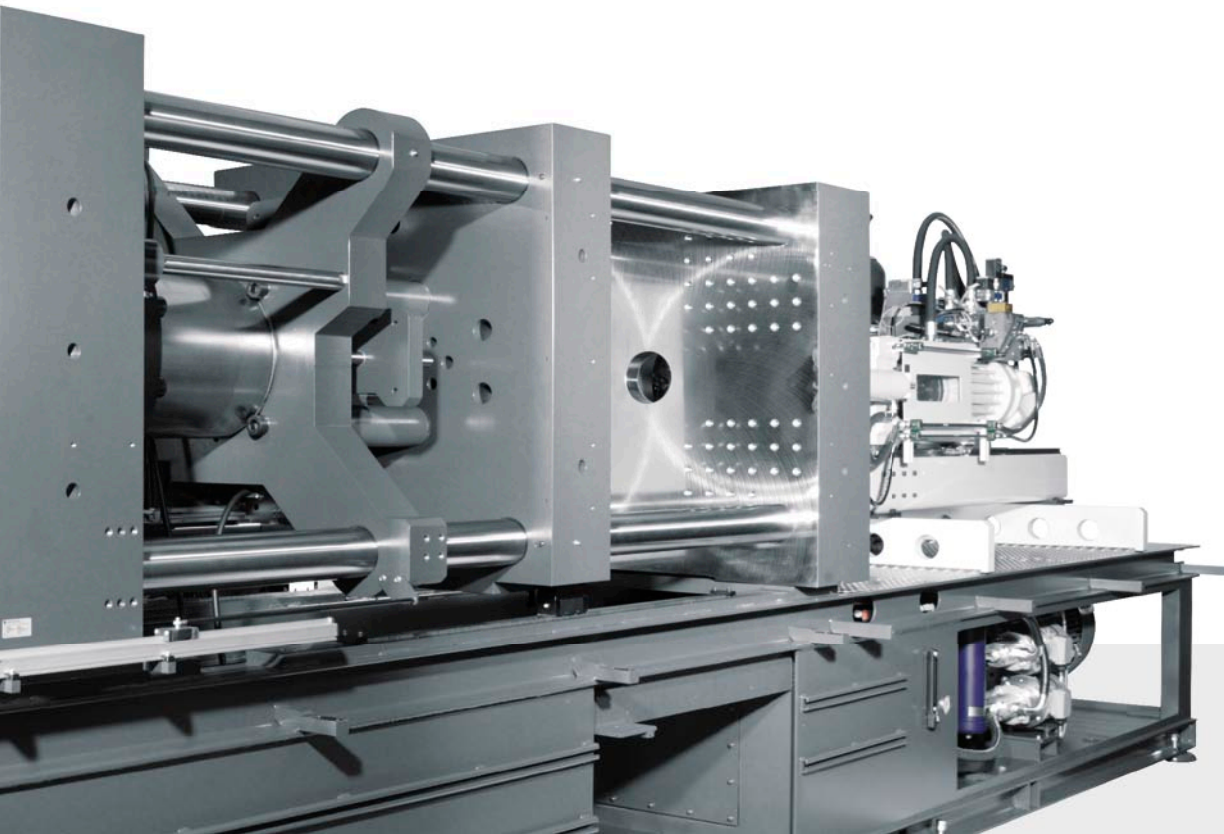

Mold Longevity Guaranteed

Exceptional platen rigidity and even force distribution mean that the clamping force can be optimized at the lowest value for minimal mold wear. Exceptional clamping unit dynamics, together with accurate mold pressure monitoring during the clamping phase, provide the best possible combination of productivity and mold protection.

Faster Set-up for Quick Production Changes

The whole injection unit assembly swivels out providing easy access to the screw and simplifying maintenance. The screw barrel can be replaced within minutes.



Injection unit swivels for easy maintenance

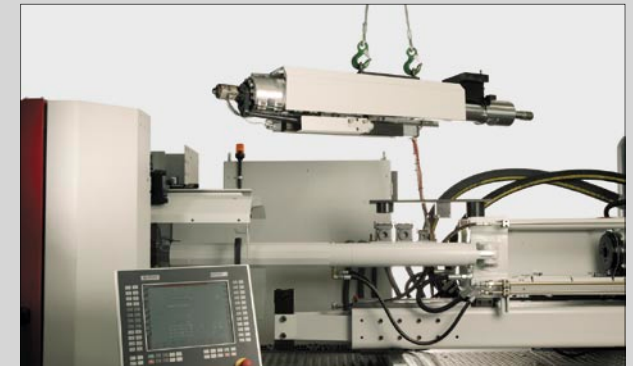

Fast screw and barrel replacement for new production tasks

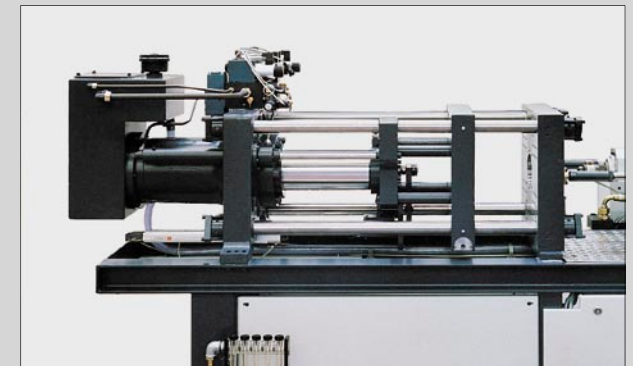

Additional mold height adjustment option by pressure bolt replacement

HIGH SPEED PERFORMANCE

Super-Fast Cycle Times

Both the fully hydraulic and hybrid versions offer parallel machine functions and are well established in the high-end markets where speed is crucial for packaging and consumer goods applications. K-TEC performance is guaranteed by:

- Smart hydraulic accumulator controls for parallel operations and higher output
 - Lower energy consumption thanks to an optimized pump drive operating in concert with the accumulators
 - Lock-free, immediate clamp force actuation
 - Reduced mass of the inline injection unit for exceptional injection speeds
 - Application-specific screws for improved plasticizing rates and higher longevity
 - Early injection mode where injection begins as soon as desired clamping force is reached
- High injection speeds for cost-saving thin wall applications
 - Optional reinforced hydro motor or electric motor for plasticizing
 - The responsive closed-loop pressure controls ensure outstanding injection repeatability

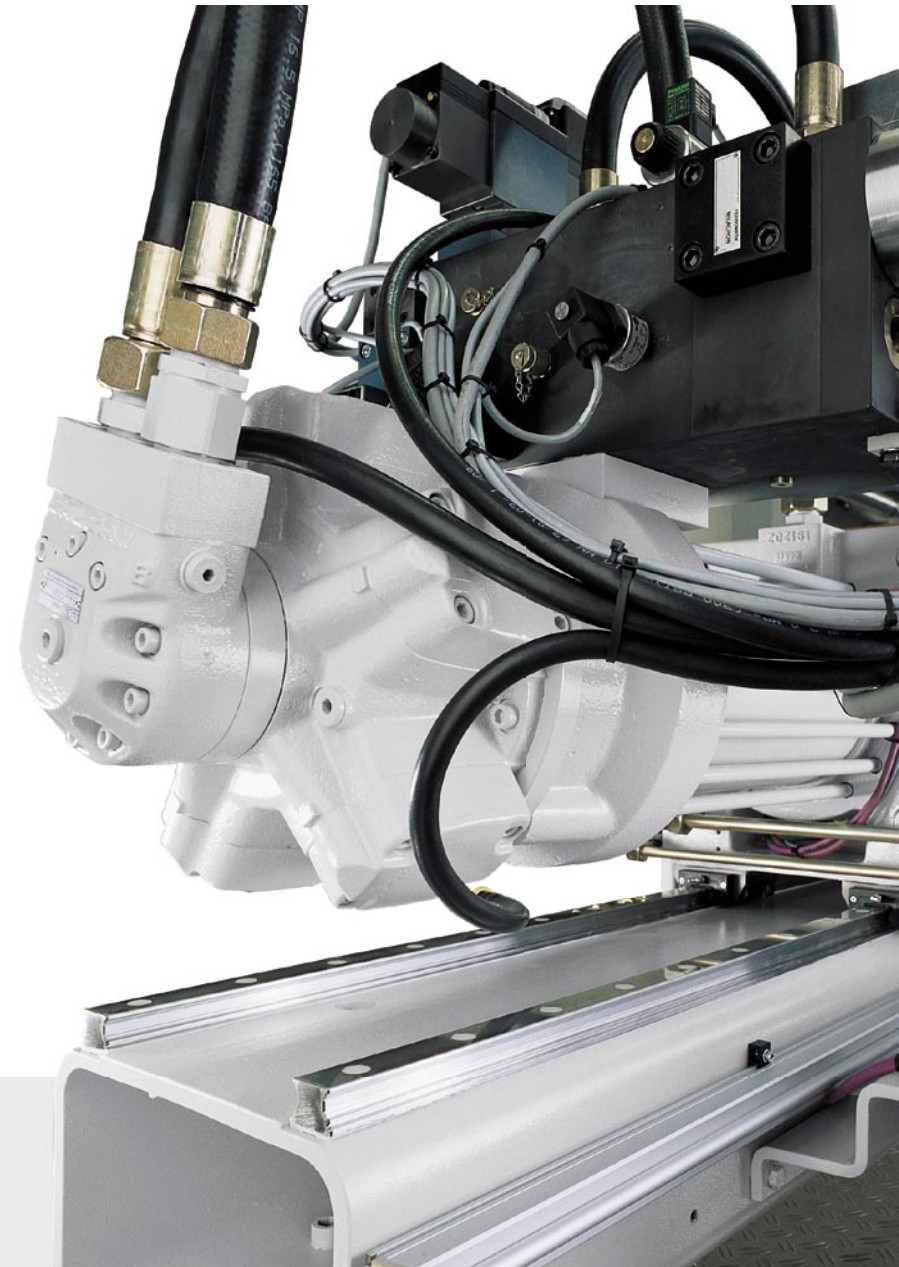



Uptime is Everything Reliability Means Productivity

Ultra high-speed performance means nothing if the machine is not operating 24/7 over the long haul. K-TEC runs and runs with minimal maintenance or service requirements. The K-TEC uptime promise is guaranteed through:

- Proven high-grade components
- Design of key elements with high safety factors
- Focus on safety in machine features and components
- High dynamic clamp safety control for best-in-class mold protection
- Constant clamping force independent of room temperature
- Exceptional process accuracy
- Clear text simplifies diagnostics
- Dedicated screw geometries, materials and surface treatment for high longevity of screws and barrels

Everything in Parallel Smart Accumulator Controls

- Clamp open/close
- Ejector
- Injection unit displacement
- Injection
- Clamping force
- Holding pressure and screw suckback
- Plasticizing

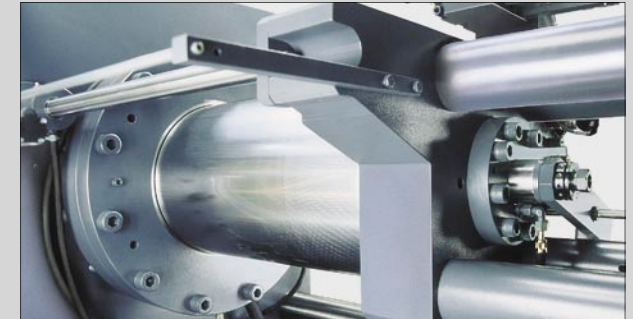

Central hydraulic clamping cylinder with easily accessible central ejector

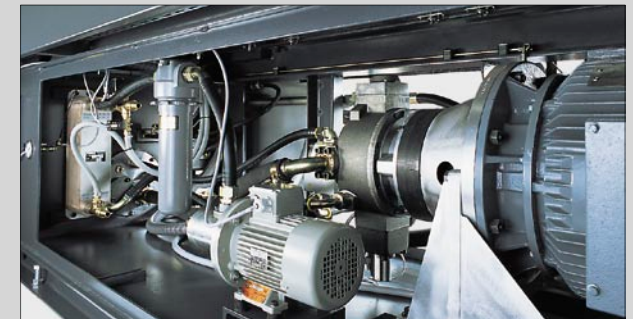

Direct access to hydraulic pump and filters



Optional electrical drive for parallel plasticizing

MOSAIC

User-Friendly Controls

The intuitive and ergonomic MOSAIC control panel was developed to provide support for all operating tasks from the simplest production routines to the most complex machine setups and optimization. A Wizard guides the operator step-by-step through the setup and programming modes. The controls use advanced networking technologies for fast and reliable communications with the machine. All processes and functions are represented graphically in the user interface, simplifying optimization. MOSAIC offers:

- Intuitive controls via large 15" touch screen terminal mounted on an adjustable swing arm for stress-free operations and natural movement
- Graphic menu controls
- Every page just one or two clicks away
- Online help for parameter optimization
- On-screen function buttons
- Freely editable mold sequence
- Detailed process monitoring with tolerances, minimum and maximum values, average, and standard deviation
- Real-time graphical representation of molding process and production cycle controls
- Easy data storage and guided machine setup
- Ethernet interface
- USB memory key for storing mold data, screenshots, and for exporting report data
- Password protected access levels ensure security
- Separate data sets for setup and optimization during machine operation





It's Magic: The Wizard

Like having an assistant by their side, the Wizard helps operators set all relevant parameters both in setup and programming mode. This simplifies tasks and greatly reduces the chances of entering incorrect settings. Wizard-based support is available for the following areas:

- Mold installation height settings
- Mold cavity pressure sensor
- Stack-turning technology, cube molds, and twin cube molds
- Editable core-pull movement and mold sequence

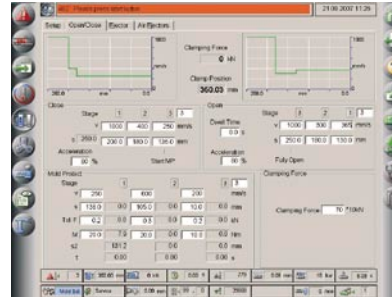

Intuitive machine setup: access to all functions in just one or two clicks

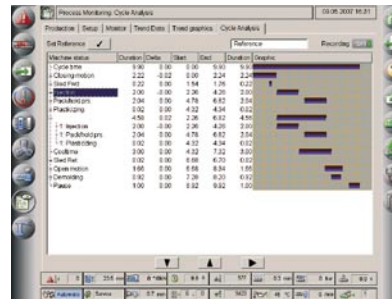

Cycle and trend analysis for fast process optimization

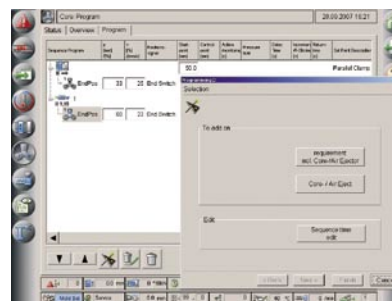

Simple programming of core-pull movements with help from the Wizard

Remote Monitoring

Thanks to the standard Ethernet interface, the machine can be monitored from any location with internet access. The following parameters can be monitored:

- Machine number and type and injection unit size
- Mold number and the type of material being processed
- Number of error messages and alarm logbook
- Current operator and operating mode
- SPS status indicator
- Shot counter
- Configurable trend data indicators
- Logbook for operator notes

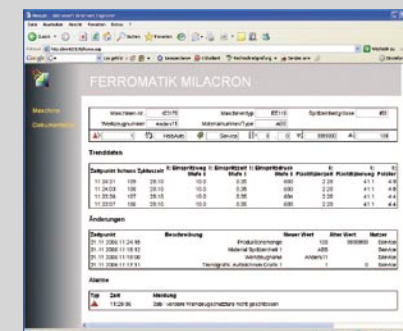

Standard in all machines: remote monitoring access

MAXIMUM FLEXIBILITY

Innovative Process and Mold Technologies

Special processes and mold technologies – in all their permutations and combinations – open up a whole new world of possibilities for innovative manufacturing solutions. These may either maximize productivity or add value to the product – while reducing production costs.

Multi-Component Technology

With multi-component technology parts multiple colors, materials, and even functions can be produced on a single machine. Many of these parts would be uneconomical – or even impossible – to produce using conventional technologies.

With the standard multi-component process, a substrate is overmolded at a second station. This step is repeated until the part is complete.

Multi-component technology requires a specially configured machine including:

- Core-pull controls for opening secondary cavity
- Activation of mold-integrated index platen for transfer of substrate

- Robotic transfer of substrate
- Integration of turntable with clamping unit

Monosandwich

The sandwich process is a simpler variant of multi-component technology. With this solution the part has a layered structure where the core material is covered with a different skin material. While conventional sandwich technologies require an additional injection unit, Ferromatik Milacron's patented monosandwich process only requires a secondary extruder, a much more economical solution.

The advantages of this technology are:

- Simple process setup
- Superior part quality thanks to exceptional repeatability and precision
- Uses existing single component molds
- Faster material and color changes

- Reduced material costs through use of economical core materials including regrind
- Perfect surface even with foamed or reinforced core materials
- Creative design solutions through innovative material combinations

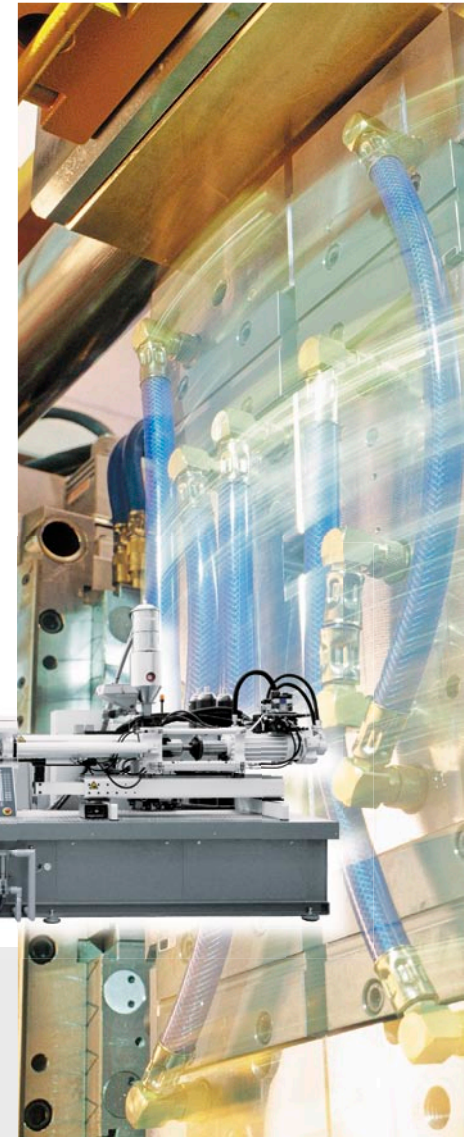
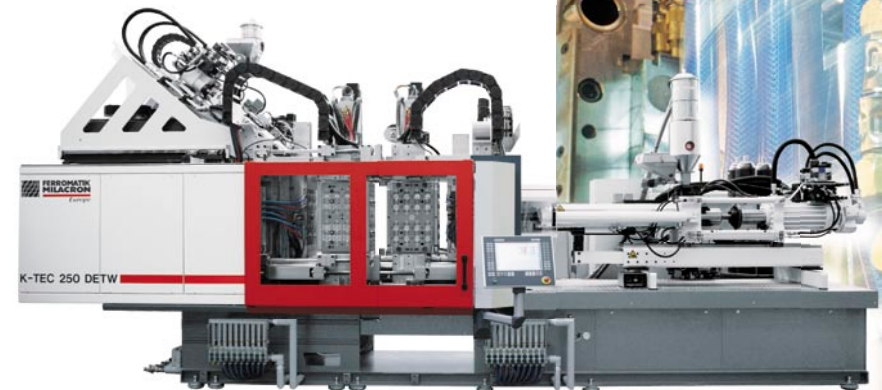

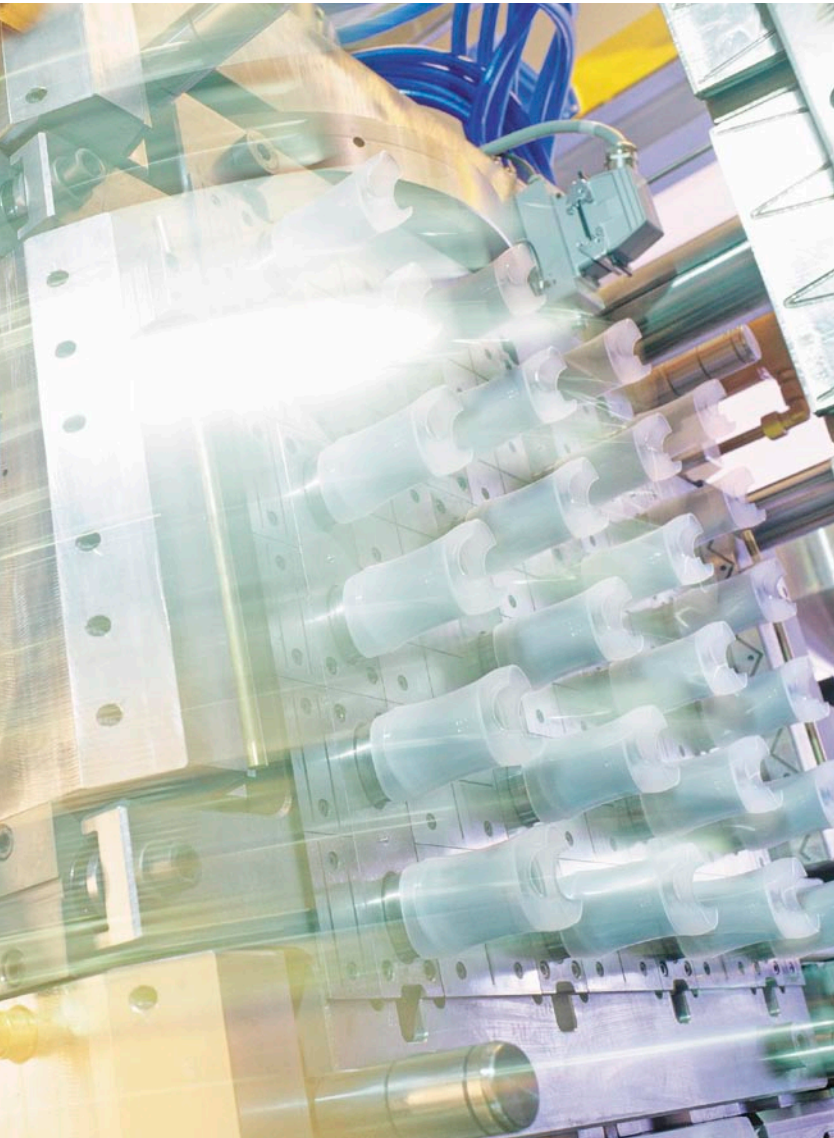

Tandem Technology

Tandem technology uses a mold with two parting lines. The cavities of the two parting lines are filled alternately. While the machine opens to remove the part from the first, a locking mechanism keeps the second parting line closed. Thus cooling time is utilized within the injection process.

For slower, thick-walled part production with long cooling times, this approach effectively doubles output. With faster production tasks and short cycles, tandem technology can still achieve productivity increases of up to 30%. The advantages:

- Reduced production costs due to increased output
- Lower capital investment through use of smaller machine sizes

Advanced Multi-Component Solutions

Cube (90° Stack-Turning Mold)

A turning mechanism with four stations offers lateral stations for additional operations such as cooling, inspection, insert molding, in-mold labeling, assembly and part removal. This high productivity solution for large multi-cavity molds offers the following advantages:

- Full platen utilization
- Double production capacity
- Reduced cycle time
- Additional lateral operations without adding to cycle time
- Rotation controls integrated with MOSAIC control panel
- Patented solution for optimum cooling

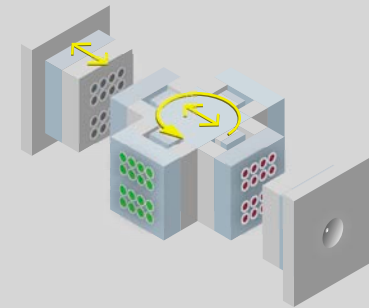

Twin Cubes (Double Stack-Turning Mold)

In addition to many advantages of cube molds, a double stack-turning mechanism allows the simultaneous production of two or more parts with automatic assembly in the middle position.

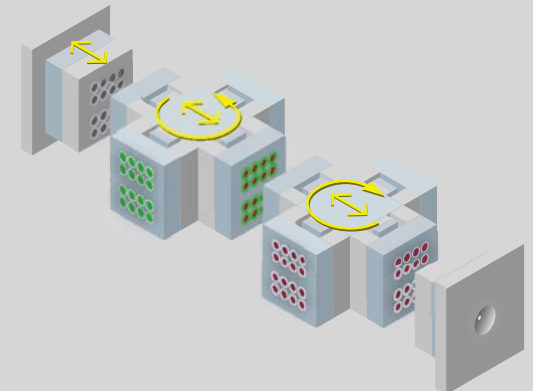

CUSTOM SOLUTIONS

Find the Perfect Match for Your Mold

With multi-cavity molds, the mold size does not always correspond to the clamp requirements. K-TEC machines can be configured to provide the perfect fit for your mold:

- Three different tie bar clearances per clamp force size allow for oversized mold
- Alternate pressure bolt lengths for additional mold height adjustment
- Multiple tie bar extensions especially for multi-component and turning stack technology
- Custom pattern for mold fixing and centering
- Easy access to ejector mechanism thanks to the design with pressure plate and pressure bolts

An Applications Expert Right at Your Door

The Ferromatik Milacron applications engineers can help you determine which technologies will best serve your requirements. From machine configuration, mold design, and peripheral equipment through complete part cost calculations, your equipment will provide the best solution available on the market for your application.

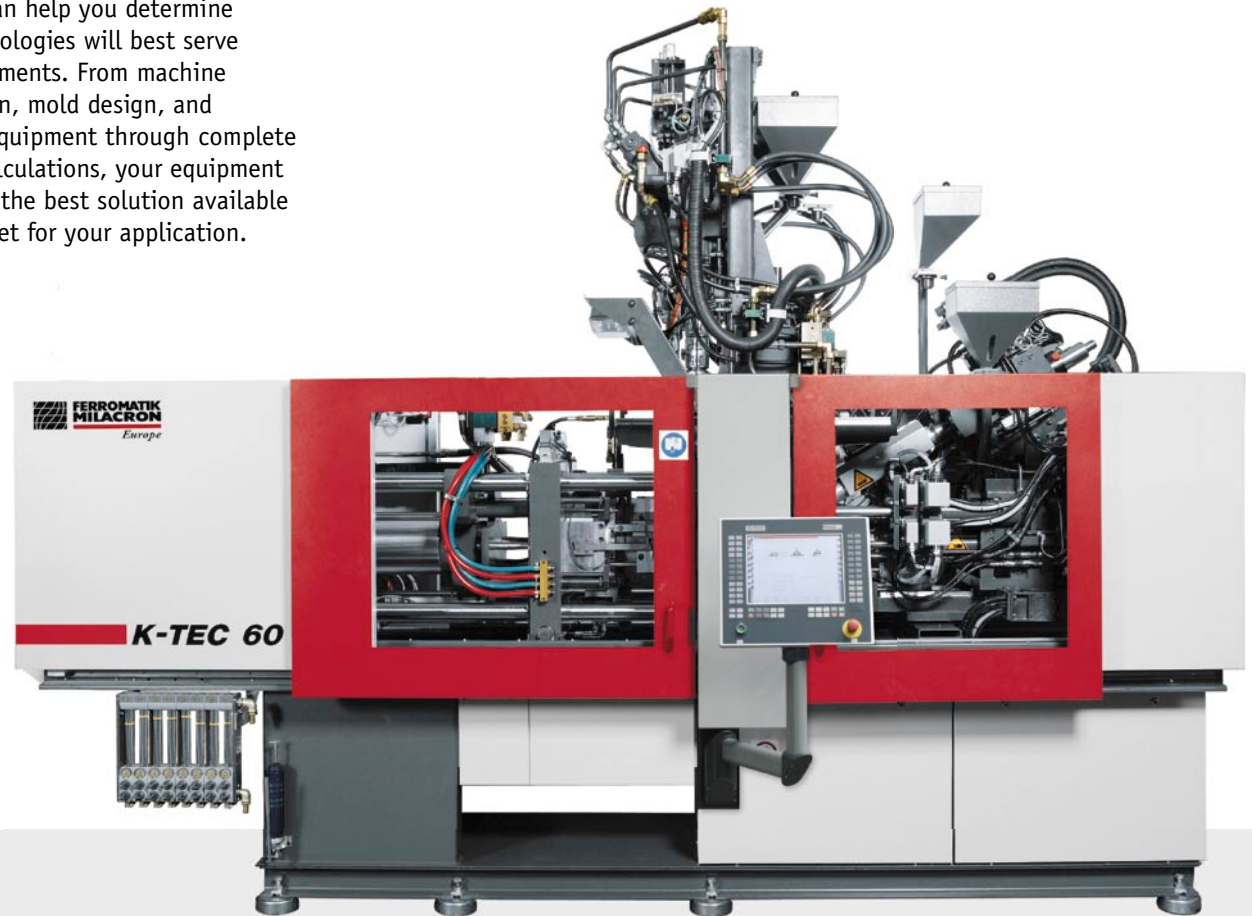

APPLICATIONS & SYSTEMS

From Idea to Finished Product

The Business Unit Applications & Systems team is ready with advice and service when you need it:

Consultations

Our experts can visit your facility to provide process and technology advice for your specific production needs. In the face of rising electricity costs, we offer comprehensive support for implementing energy saving programs.

Injection Molding Trials

Our state-of-the-art Technology Center includes a variety of injection molding machines for trials. You can use your own molds and even run pre-productions.

Acceptance Test

At the time of the purchase, we would be happy to include an acceptance test in our factory to insure that the machine meets the requirements of your application.

Process Service

If process problems arise, our trained technicians will come to your facility to identify and correct any issue and get you up and running again with minimum interruption.

Production Designs

We would be happy to develop individual solutions for your production needs. These extend from the choice and configuration of the machine to the right technologies, screw, mold, and auxiliary equipment. Our calculation tools allow us to provide comparative part costs for different solutions.



The Technology Center in Malterdingen

System Solutions

Depending on your requirements, we work with industry-leading partners to provide full turnkey production systems including the machine, the mold, and auxiliary equipment.

Research and Development

Our engineers are continually at work developing innovative new solutions and the technologies of tomorrow.

Training

We offer various courses year-round in machine setup, process optimization, maintenance, and repairs at our Training Center. We also provide training programs in your facility.

SERVTEK

Now under the SERVTEK name, the specialists at Ferromatik Milacron are setting new standards in customer service:

Flexible Service Contracts

Service contracts are available for both new and existing machines and can be tailored to your specific requirements. Service contracts assure maximum availability and long machine life.

Adapting Single-Component Machines for Multi-Component Molding

Existing machines can be upgraded with the addition of a stand-alone injection unit for multi-component molding. This can also be done with machines built by other manufacturers.

New Life for Old Production Cells

Overhauling and modernizing older machines is routine for our professionals.

Optimum Screw Selection for High Output

Depending on the application and the material, a variety of screw designs, screw tip assemblies, and barrels are available for improving plasticizing performance.

Phone Support Around the Clock

Extended phone support is available for fast answers to technical questions.

Replacement Parts within Hours

In addition to our central facility in Germany, we have local parts warehouses around Europe, Asia, and the US so that all available parts will be at your location within 24 hours.



Global Partners in Plastics

